

4AM160S4-024-001

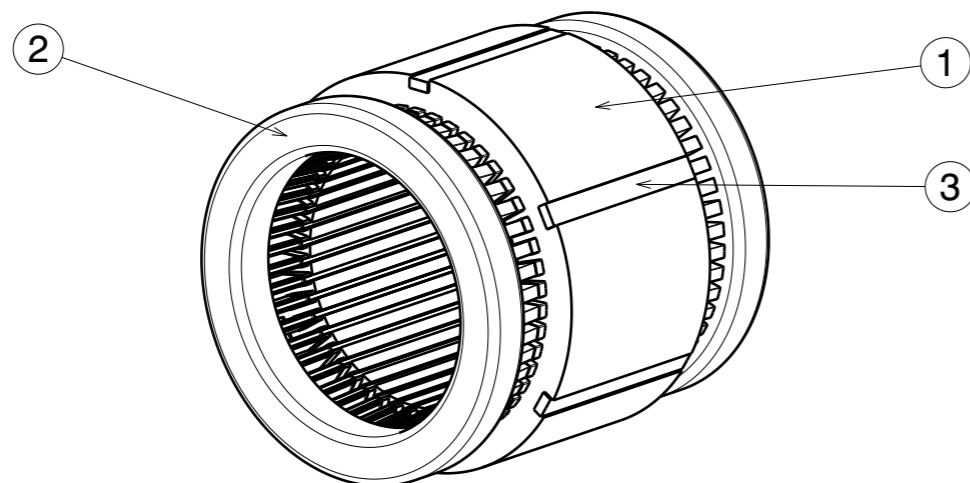
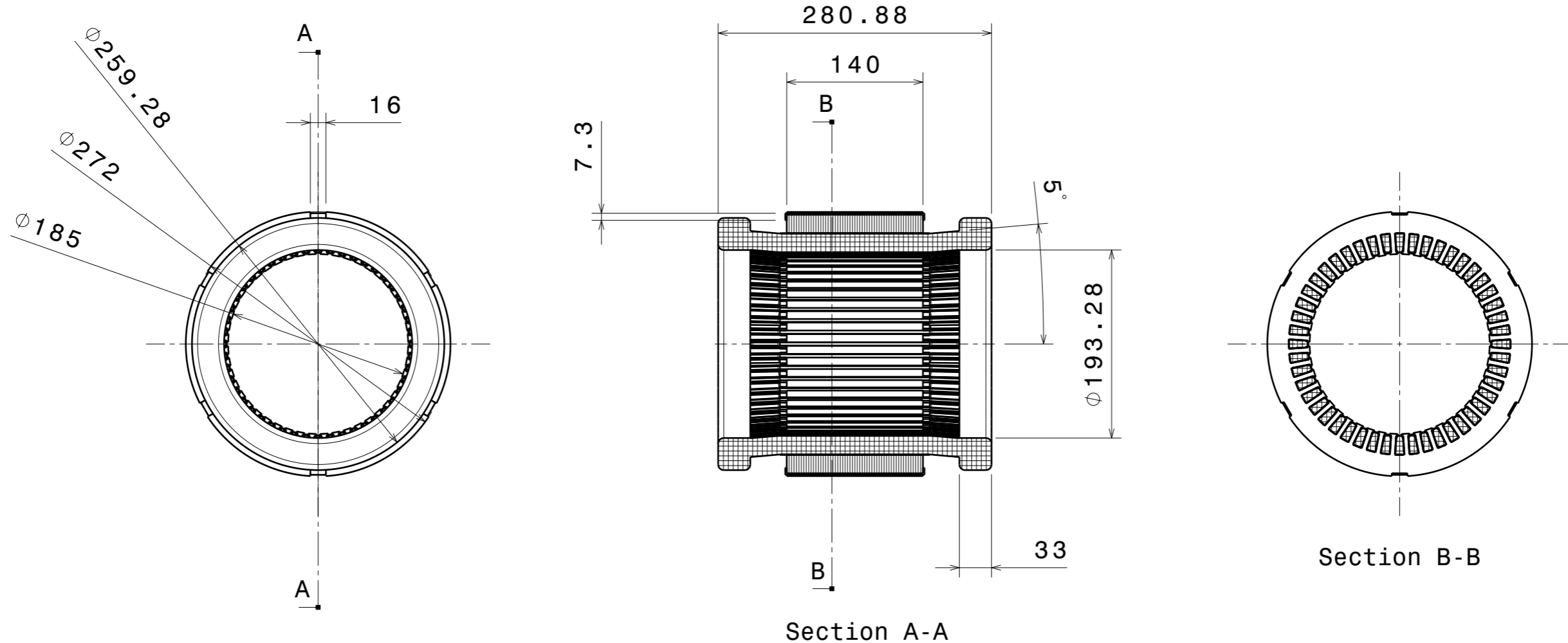

If not specified, tolerance of +/-0.1mm must be used.  
 Sharp edges must be removed.  
 This drawing cannot be reproduced or communicated without written agreement of Dr. A.Pulnikov.

Use	Num. 3	Sign. & date	Num. 2	Num. 1	Sign. & date	Num.
-----	--------	--------------	--------	--------	--------------	------

Item	Qty	Unit	Part-No	Description	Remarks
1	24.5	kg	4AM160S4-021-001	Stator lamination stack M250-50A	
2	17.6	kg	4AM160S4-023-001	Stator winding	Y connection
3	6	pc		Brackets	

					<b>4AM160S4-024-001</b>			
Mod	Sh.	N. doc	Sign.	Date	<b>Stator (laminated core with winding)</b>	Let	Weight	Scale
Design		Müller	4/12/2019				42.4	1:5
Checked		Schmidt				Sheet 1	Sheets 1	
Control						Pulnikov EC		
Depart.					Different materials			
Control					Pulnikov EC			
Appr.		Pulnikov			1 Pulnikov EC			