

4A112M4-022-001

Use

Num. 3

B

A

Sign. & date

Num. 2

Num. 1

Sign. & date

Num.

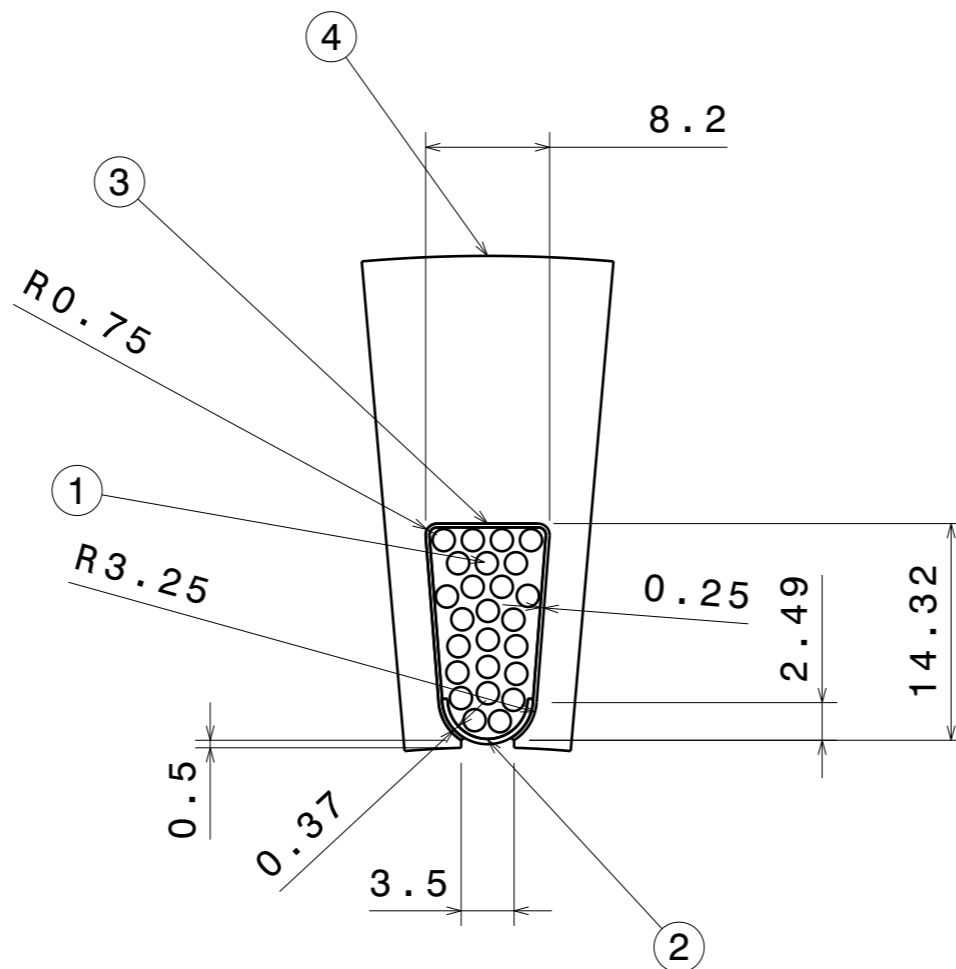

If not specified, tolerance of +/-0.1mm must be used.

Sharp edges must be removed.

This drawing cannot be reproduced or communicated without written agreement of Dr. A.Pulnikov.

Item	Qty	Unit	Part-No	Description	Remarks
1	25	pc		Insulated copper wire	1.468mm
2	1	pc		Plastic wedge	Thickness=0.35mm
3	1	pc		Slot insulation	Thickness=0.25mm
4	1	pc	4A112M4-021-001	Stator lamination	Steel-2013

					4A112M4-022-001			
Mod	Sh.	N. doc	Sign.	Date	Stator slot with wedge and insulation	Let	Weight	Scale
Design		Pulnikov	17/06/2020				-	2:1
Checked						Sheet 1	Sheets 1	
Control						Pulnikov EC		
Depart.					-			
Control					-			
Appr.					-			