

4A132M6-022-001

Use

Num. 3

B

A

Sign. & date

Num. 2

Num. 1

Sign. & date

Num.

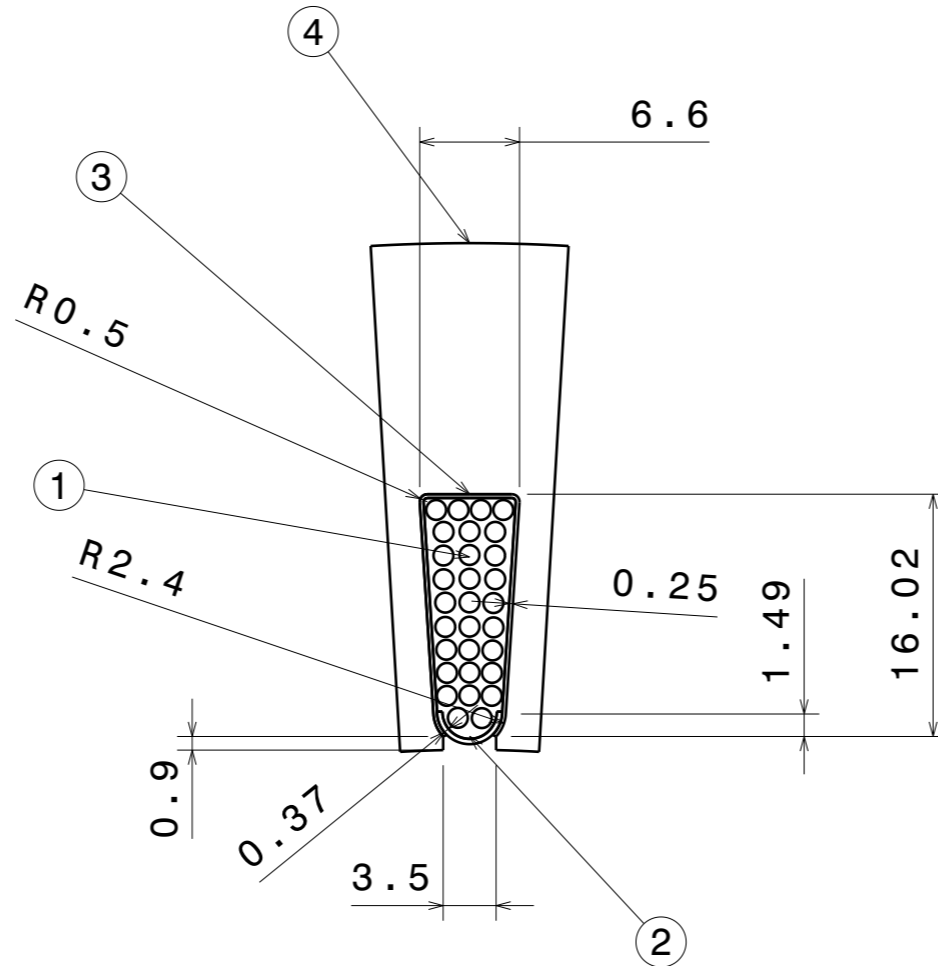

If not specified, tolerance of +/-0.1mm must be used.

Sharp edges must be removed.

This drawing cannot be reproduced or communicated without written agreement of Dr. A.Pulnikov.

Item	Qty	Unit	Part-No	Description	Remarks
1	30	pc		Insulated copper wire	1.316mm
2	1	pc		Plastic wedge	Thickness=0.35mm
3	1	pc		Slot insulation	Thickness=0.25mm
4	1	pc	4A132M6-021-001	Stator lamination	Steel-2013

Mod	Sh.	N. doc	Sign.	Date
		Pulnikov	17/06/2020	
		Checked		
		Control		
		Depart.		
		Control		
		Appr.		

4A132M6-022-001

Stator slot with wedge and insulation

Let Weight Scale

- 2:1

Sheet 1 Sheets 1

Pulnikov EC