

4AM160S4-010-001

Use

Num. 3

B

A

Sign. & date

Num. 2

Num. 1

Sign. & date

Num.

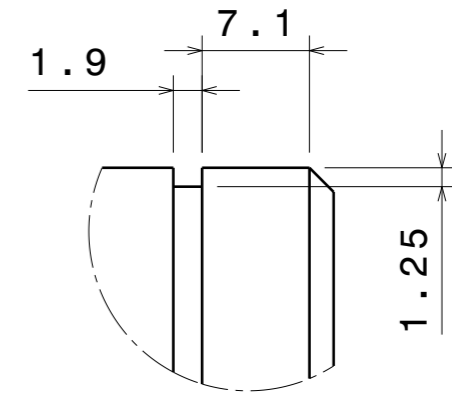
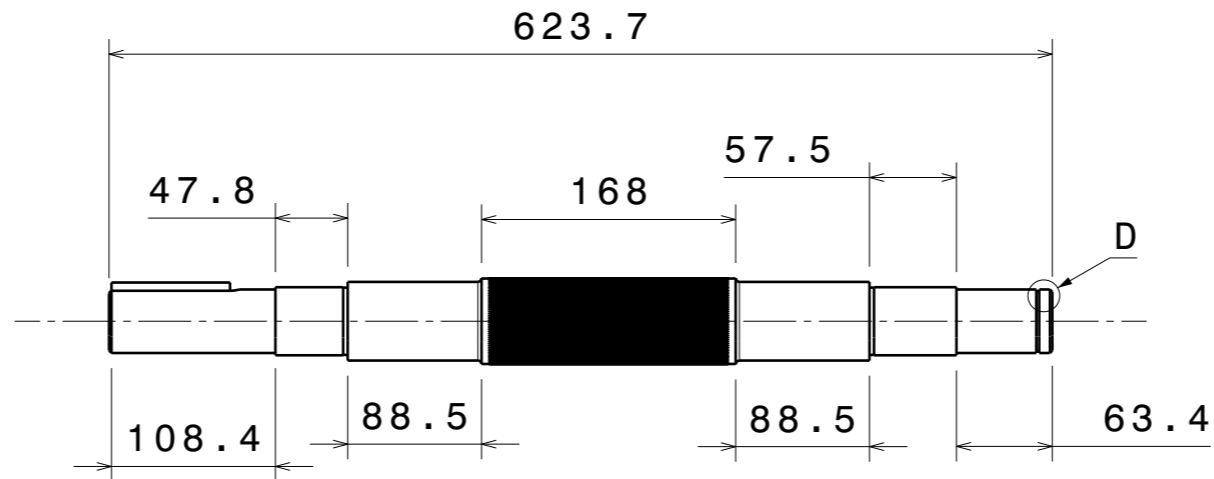
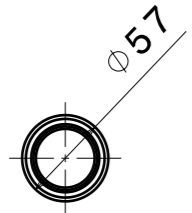

Detail view D
Scale 2:1

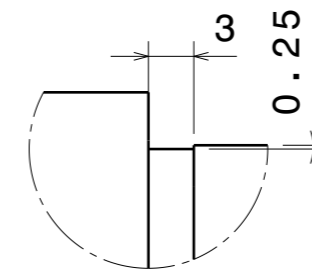

Detail view G
Scale 2:1

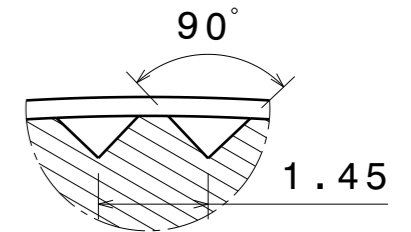

Detail view F
Scale 10:1

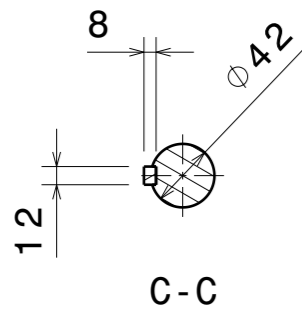

C-C

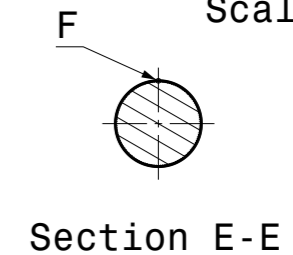
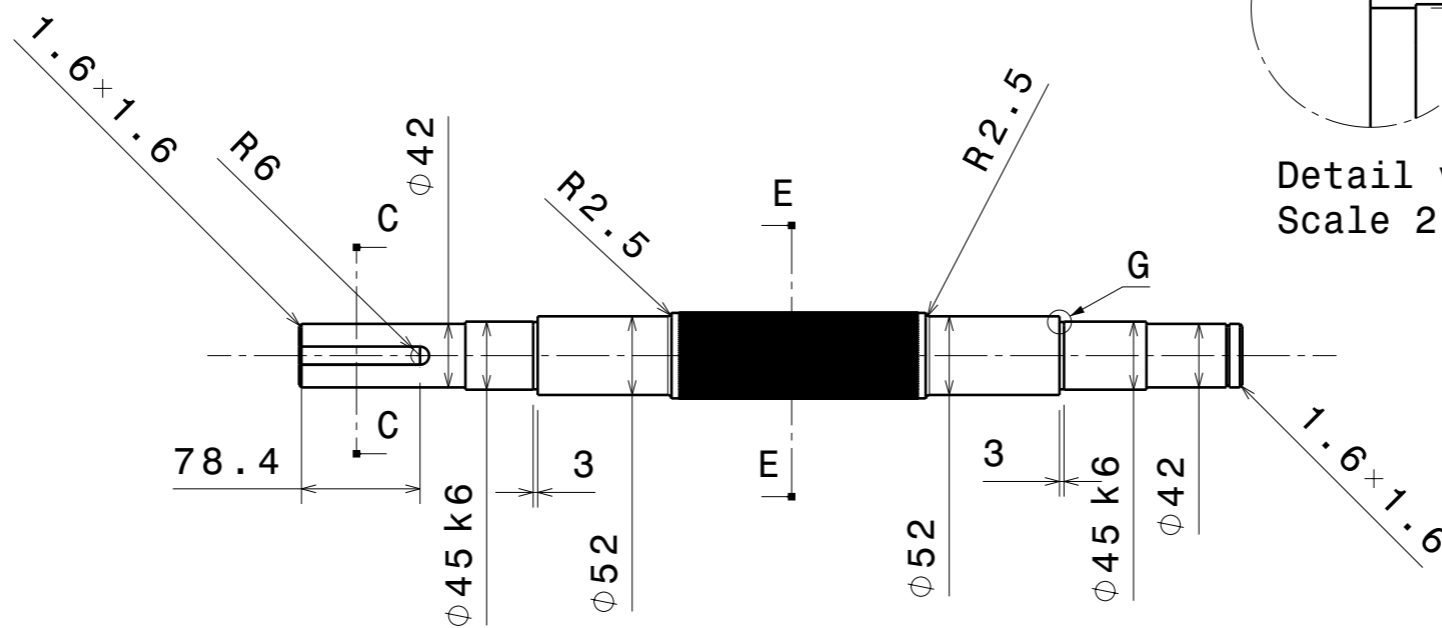

Section E-E

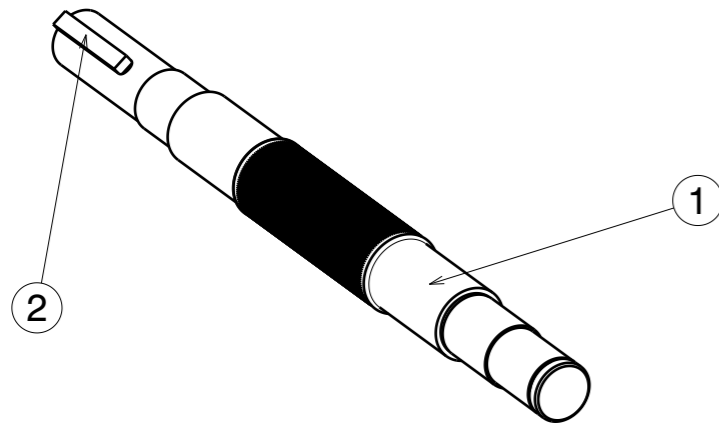

If not specified, tolerance of +/-0.1mm must be used.

Sharp edges must be removed.

This drawing cannot be reproduced or communicated without written agreement of Dr. A.Pulnikov.

Item	Qty	Unit	Part-No	Description	Remarks
1	1	pc		Shaft	Steel
2	1	pc		Cotter	Steel

					4AM160S4-010-001			
Mod	Sh.	N. doc	Sign.	Date	Shaft and cotter	Let	Weight	Scale
Design		Müller	4/12/2019				9.46	1:5
Checked		Schmidt						
Control						Sheet 1	Sheets 1	
Depart.					Steel	Pulnikov EC		
Control								
Appr.		Pulnikov						