

4AM160S4-032-001

Use

Num. 3

Sign. & date

Num. 2

Num. 1

Sign. & date

Num.

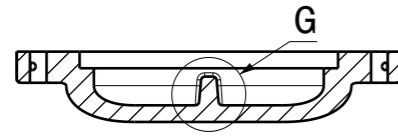

Section F-F

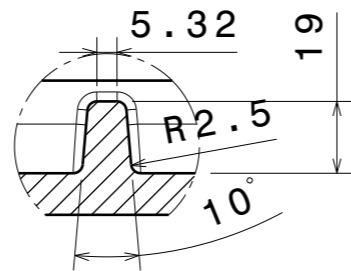

Detail view G
Scale 1:2

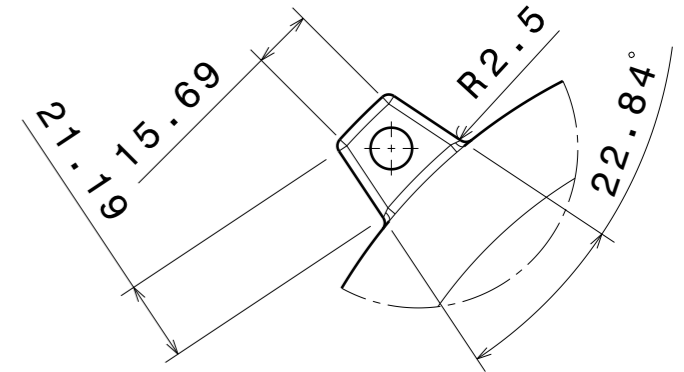

Detail view E
Scale 1:2

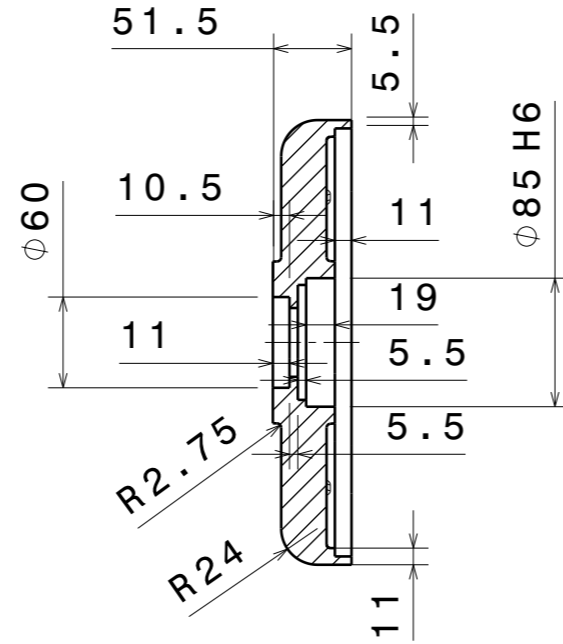
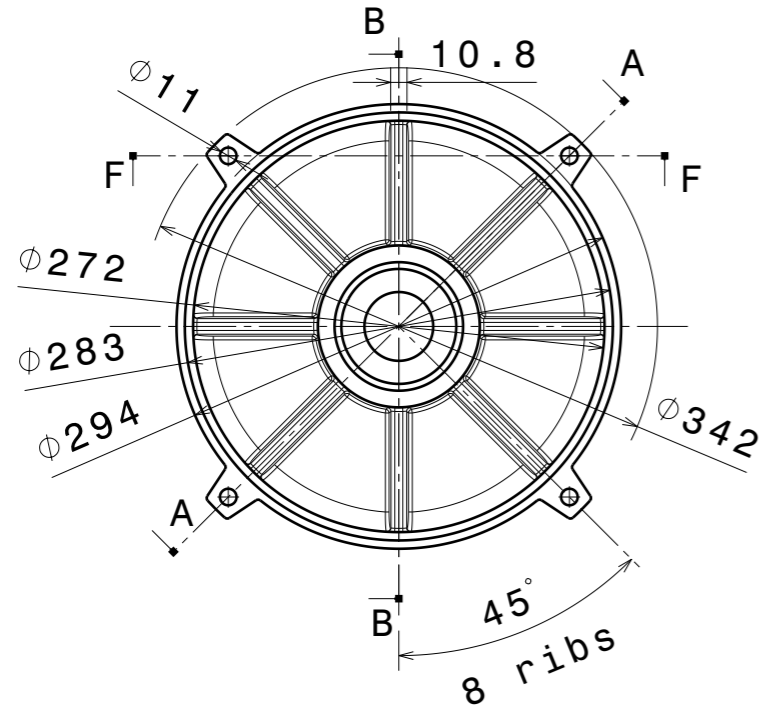

Section B-B

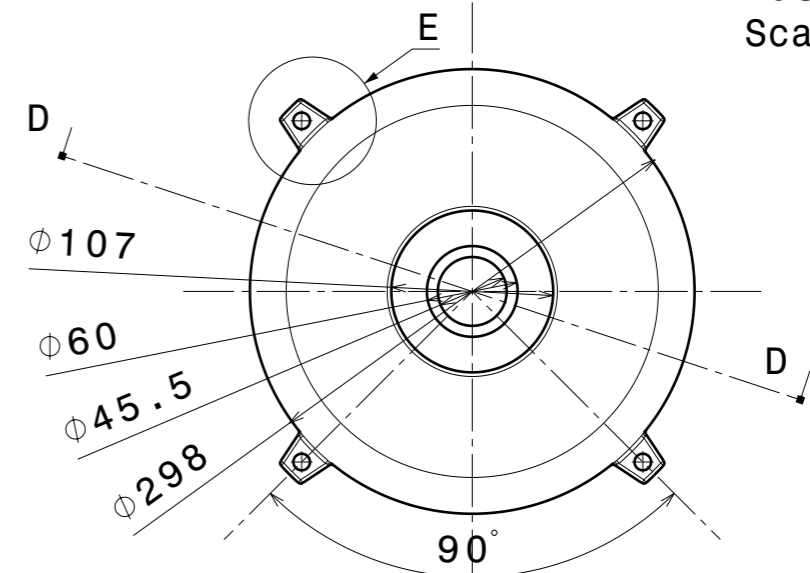

4 protrusions

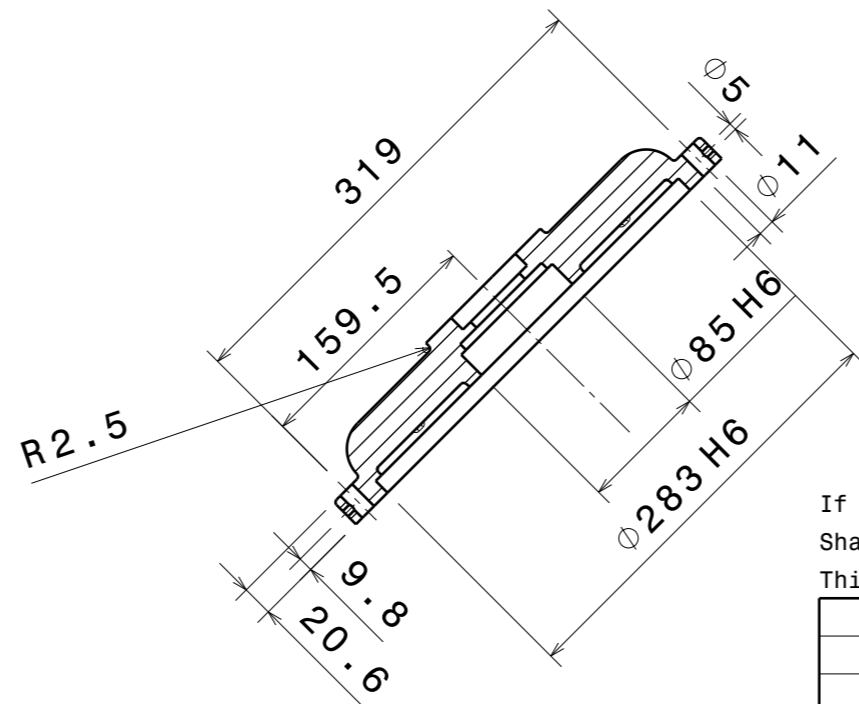
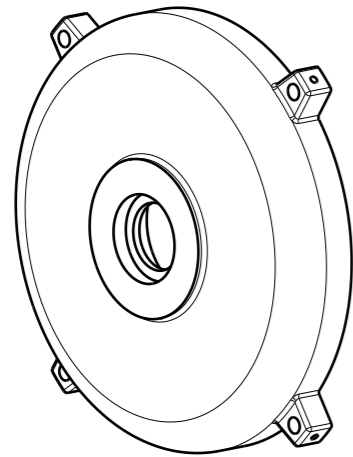

Section A-A

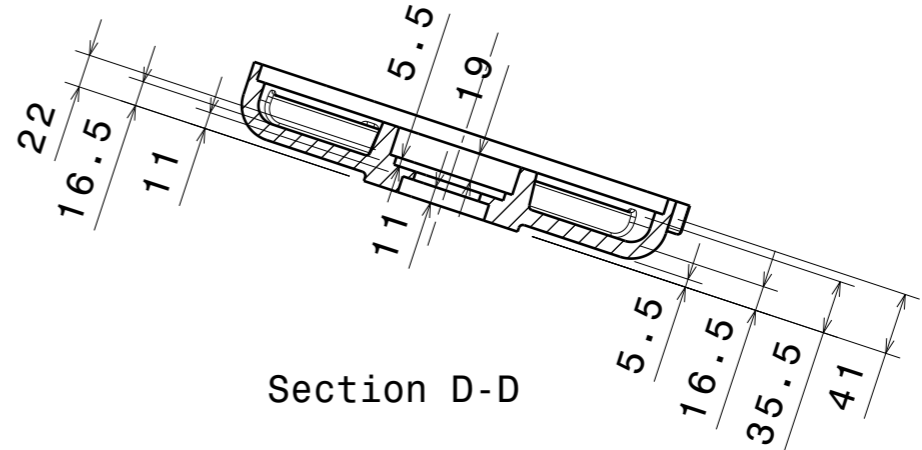

Section D-D

If not specified, tolerance of +/-0.1mm must be used.
Sharp edges must be removed.
This drawing cannot be reproduced or communicated without written agreement of Dr. A.Pulnikov.

				4AM160S4-032-001			
Mod Sh.	N. doc	Sign.	Date	Bearing shield fan side	Let	Weight	Scale
Design	Müller	5/12/2019				9.83	1:5
Checked	Schmidt				Sheet 1	Sheets 1	
Control					Cast iron		
Appr.	Pulnikov				Pulnikov EC		