

4AM160S4-033-001

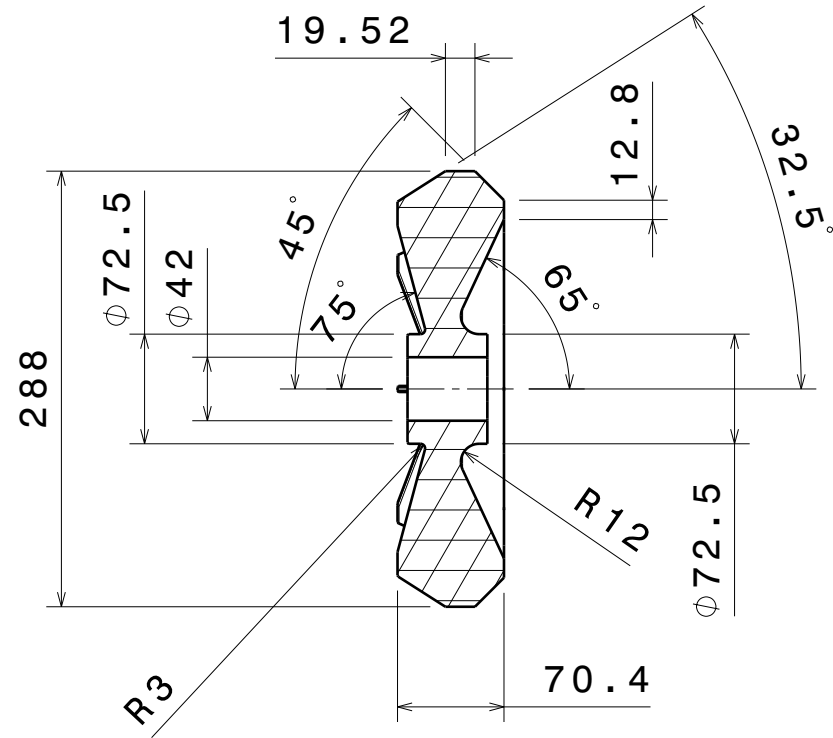

Section A-A

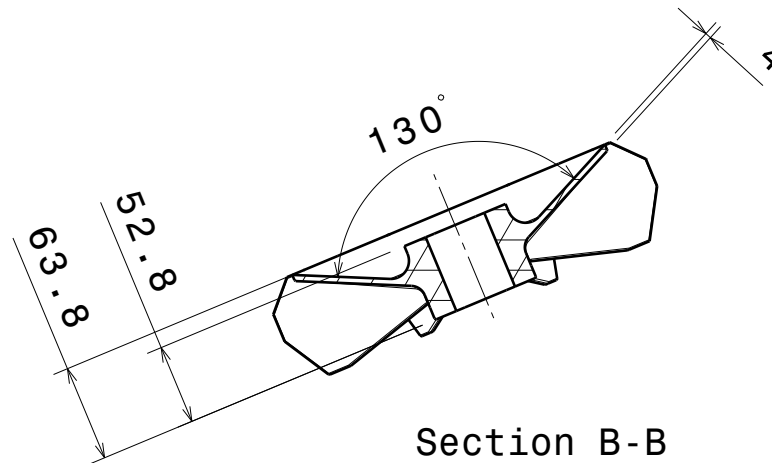
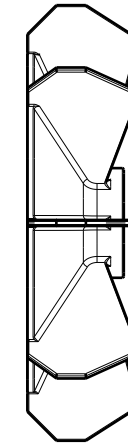
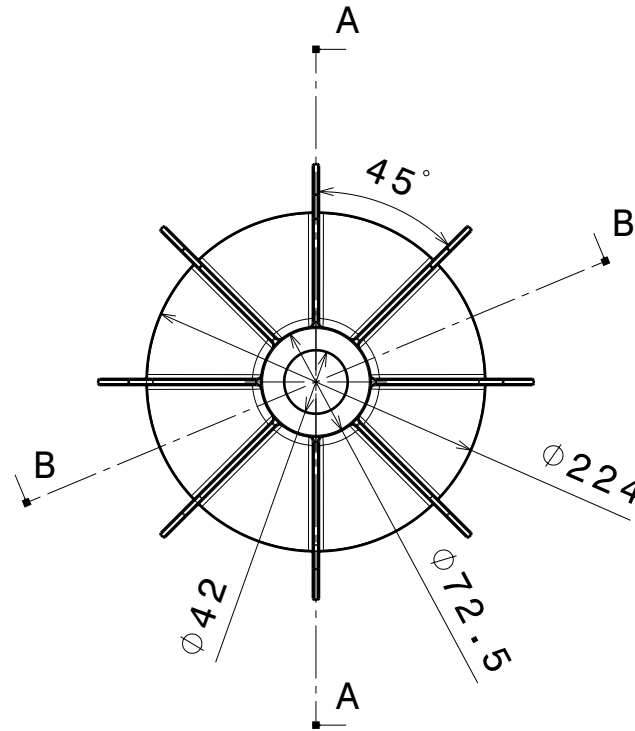

Section B-B

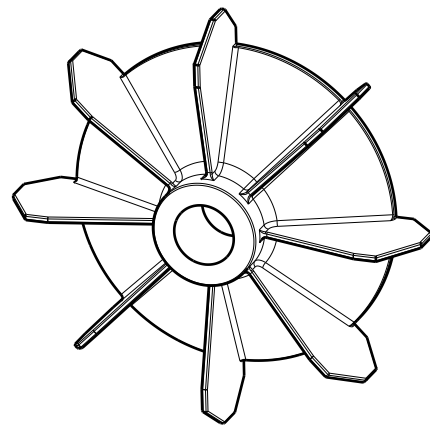

If not specified, tolerance of +/-0.1mm must be used.

Sharp edges must be removed.

This drawing cannot be reproduced or communicated without written agreement of Dr. A.Pulnikov.

					4AM160S4-033-001			
					Fan	Let	Weight	Scale
							0.67	1:5
Mod	Sh.	N. doc	Sign.	Date				
		Müller		10/12/2019				
Design		Schmidt						
Checked								
Control								
Depart.								
Control								
Appr.		Pulnikov						
					Plastic		Pulnikov EC	

Use

Num. 3

B

A

Sign. & date

Num. 2

Num. 1

Sign. & date

Num.