

4A132M6-021-001

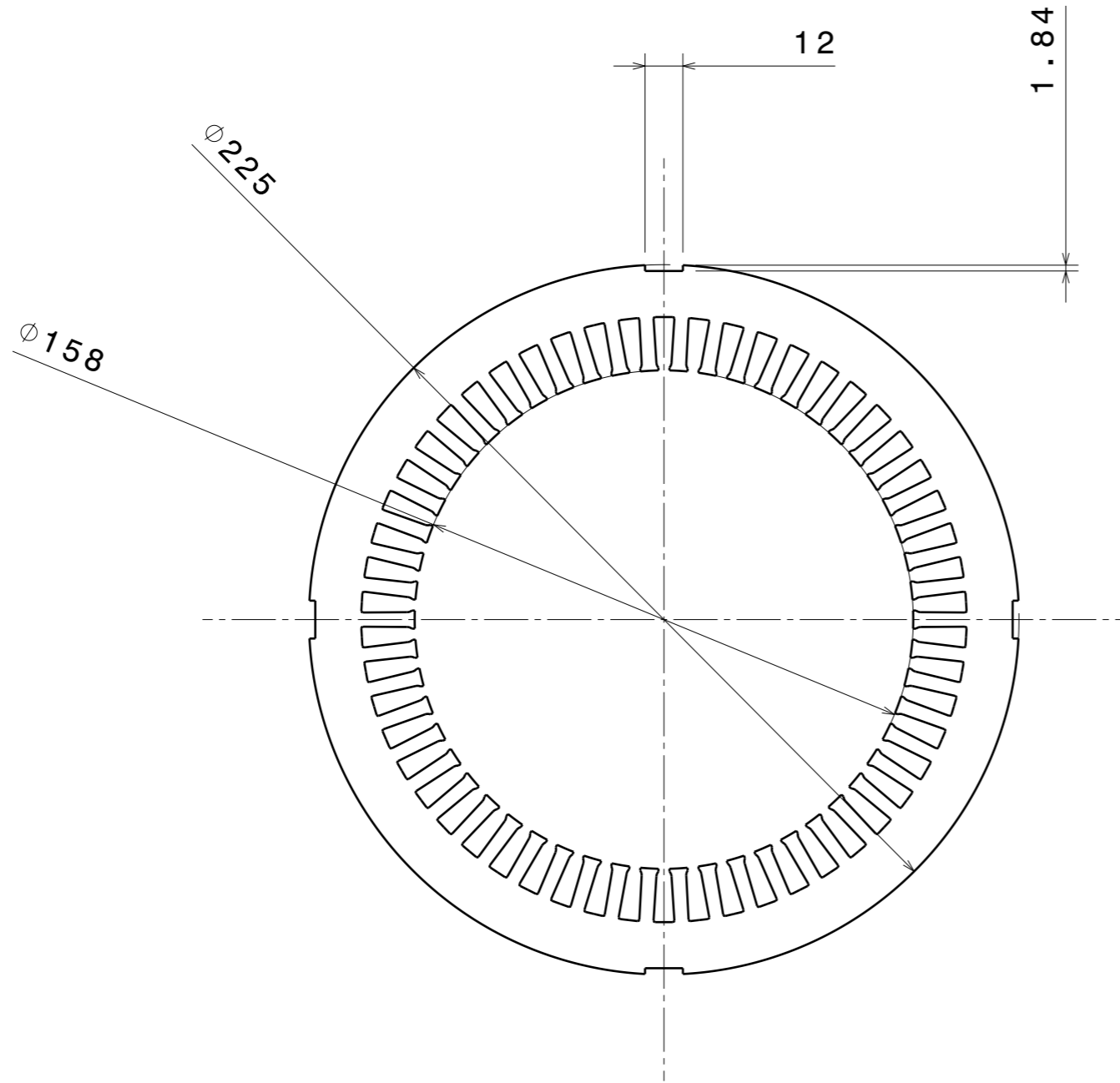

If not specified, tolerance of +/-0.1mm must be used.

Sharp edges must be removed.

This drawing cannot be reproduced or communicated without written agreement of Dr. A.Pulnikov.

					4A132M6-021-001			
					Stator lamination	Let	Weight	Scale
							0.059	1:2
						Sheet 1	Sheets 1	
					Steel-2013	Pulnikov EC		

Number of slots for winding: 54

Geometry of slots: 4A132M6-022-001

Use

Num. 3

B

A

Sign. & date

Num. 2

Num. 1

Sign. & date

Num.